

POLYMER COVER MARKED "TRAFFIC SIGNAL" STEEL PULL BOX COVER, DRAWING NO. 709 IS PREFERRED FOR ALL USES, THIS PULL BOX ONLY.

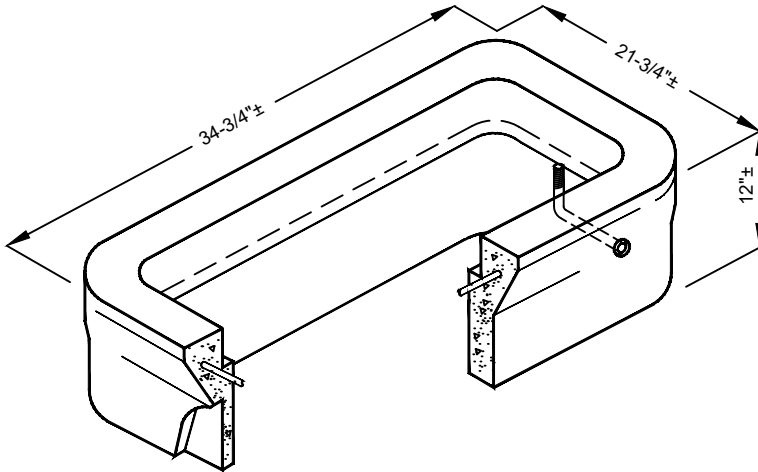

PRECAST REINFORCED CONCRETE BODY

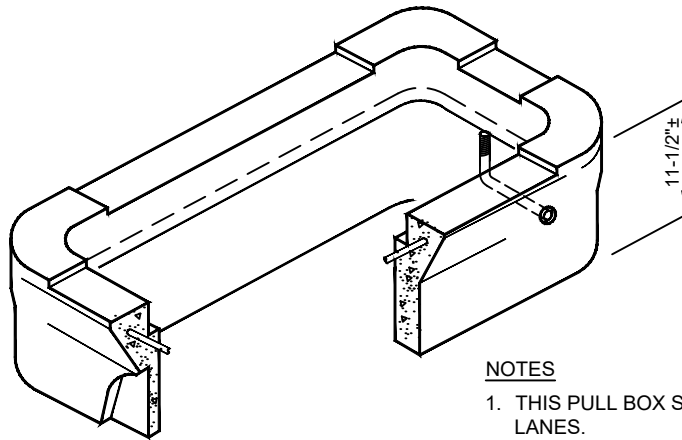

PRECAST REINFORCED CONCRETE EXTENSION (MUST NOT BE USED UNLESS SPECIFIED)

NOTES

1. THIS PULL BOX SHALL NOT BE USED IN TRAFFIC OR PARKING LANES.
2. SEE DRAWING NO. 709 FOR ALTERNATE COVER.
3. TOP OF UTILITY BOXES INSTALLED IN SIDEWALK SHALL HAVE NO VERTICAL SURFACE DISCONTINUITIES GREATER THAN 1/4" WITH ADJACENT SIDEWALK, HAVE NO GAPS GREATER THAN 1/2", REGARDLESS OF CONSTRUCTION TOLERANCES, AND BE FIRM, STABLE, AND SLIP RESISTANT.

AGENCY APPROVED	B	C	H	L	M	N	R
-----------------	---	---	---	---	---	---	---

SPECIFICATION REFERENCE	

UNIFORM STANDARD DRAWINGS
CLARK COUNTY AREA

NO. 7 PULL BOX

DATE 01-09-20	DWG. NO. 707
---------------	--------------