

PLAN

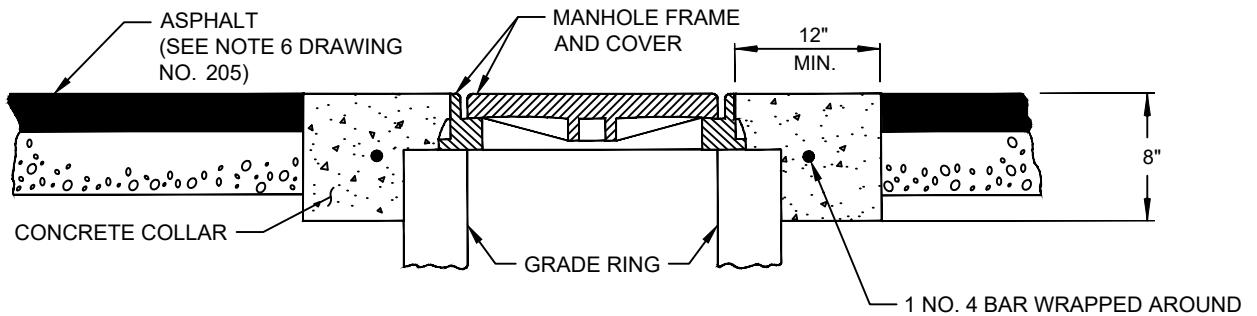

SECTION A-A

NOTES

1. CONCRETE COLLAR, FRAME, AND COVER SHALL BE CONSTRUCTED 1/8" BELOW THE ADJACENT SURFACE, $\pm 1/16"$.
2. CONCRETE COLLAR NOT REQUIRED IN UNINCORPORATED CLARK COUNTY RESIDENTIAL STREETS LESS THAN 80' R/W WIDTH.
3. IF MANHOLE IS MORE THAN 1-1/2" ABOVE OR BELOW THE ADJACENT ROADWAY SURFACE, MANHOLE SHALL BE ADJUSTED TO GRADE BY UTILITY OWNER.
4. IF MANHOLE IS MORE THAN 1/4" ABOVE OR BELOW THE ADJACENT ROADWAY SURFACE IN A BICYCLE LANE, MANHOLE SHALL BE ADJUSTED TO GRADE BY UTILITY OWNER.
5. THE USE OF 30" RING AND COVER SHALL BE APPROVED BY THE ENTITY ENGINEER.
6. WHEN INSTALLED WITHIN PEDESTRIAN ACCESS ROUTES, TOP OF MANHOLE COVERS SHALL HAVE NO VERTICAL SURFACE DISCONTINUITIES GREATER THAN 1/4" WITH ADJACENT SURFACE, HAVE NO GAPS GREATER THAN 1/2" REGARDLESS OF CONSTRUCTION TOLERANCES, AND BE FIRM, STABLE, AND SLIP RESISTANT.

AGENCY APPROVED					L		
-----------------	--	--	--	--	---	--	--

SPECIFICATION REFERENCE	
501	CONCRETE
505	REINFORCING STEEL

UNIFORM STANDARD DRAWINGS CLARK COUNTY AREA	
SUPPLEMENTAL DRAWING	
CONCRETE COLLAR AROUND MANHOLES 30 INCH RING AND COVER	
DATE 01-09-20	DWG. NO. 408.1.S1