

TYPICAL CENTERLINE DELINEATION AROUND OBSTRUCTION

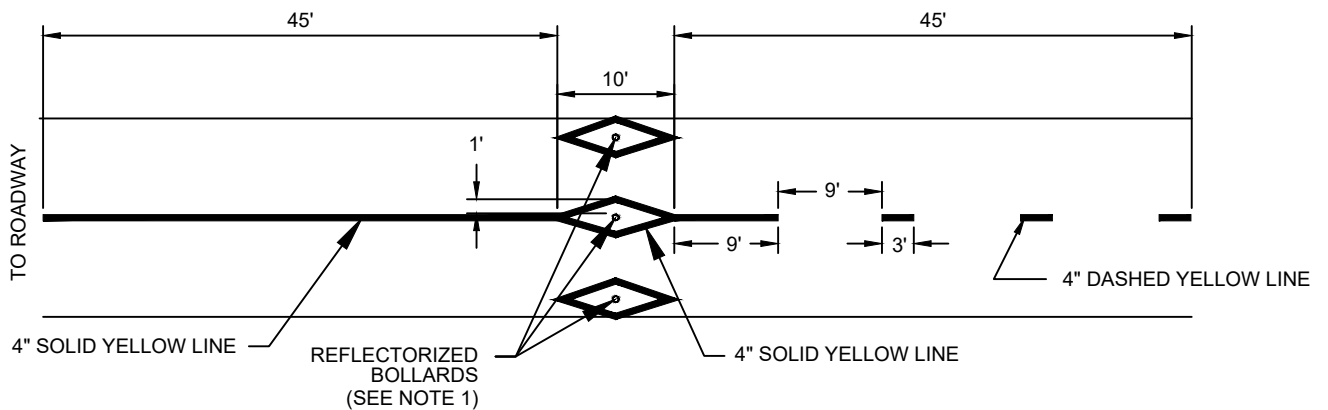

TYPICAL CENTERLINE DELINEATION AT THE BEGINNING AND END OF A SHARED USE PATH

NOTES

1. USE BOLLARDS ONLY AT LOCATIONS WHERE UNAUTHORIZED ACCESS IS ANTICIPATED. INSTALL EITHER 1 OR 3 (5 FT. SPACING DESIRABLE, 4 FT. CLEAR SPACING MINIMUM) SIX-INCH DIAMETER BY 3 FT. TALL REFLECTORIZED BOLLARDS WHEN NECESSARY. CENTERLINE DELINEATION SHOULD BE PROVIDED AT APPROACH TO INTERSECTION EVEN WHEN BOLLARD IS NOT PROVIDED.
2. ANY OBSTRUCTION IN PATH SHOULD BE REMOVED. IF OBSTRUCTION CANNOT BE REMOVED, OBSTRUCTION MUST BE REFLECTORIZED.
3. USE CENTERLINE DELINEATION AT APPROACHES TO INTERSECTIONS AND AROUND OSTRUCTIONS IN ALL CASES. ONLY USE CENTERLINE DELINEATION IN OTHER CASES WHERE CONFLICTS BETWEEN USERS TRAVELING IN OPPOSITE DIRECTIONS ARE ANTICIPATED.

AGENCY APPROVED	B	C	H	L	M	N	R
-----------------	---	---	---	---	---	---	---

SPECIFICATION REFERENCE	
628	TRAFFIC STRIPING
633	PAVEMENT MARKERS

UNIFORM STANDARD DRAWINGS CLARK COUNTY AREA	
DELINEATION AND BOLLARD USAGE ON SHARED USE PATH	
DATE 03-12-20	DWG. NO. 255.4