

1/2" EXPANSION JOINT AT 30' INTERVALS, AT COLD JOINTS AND AT BEGINNING AND END OF RETURN.
EXPANSION JOINTS TO MATCH LOCATION MATCH LOCATION OF CURB AND GUTTER EXPANSION JOINT.

PLAN

PREMOLD EXPANSION JOINT FILLER

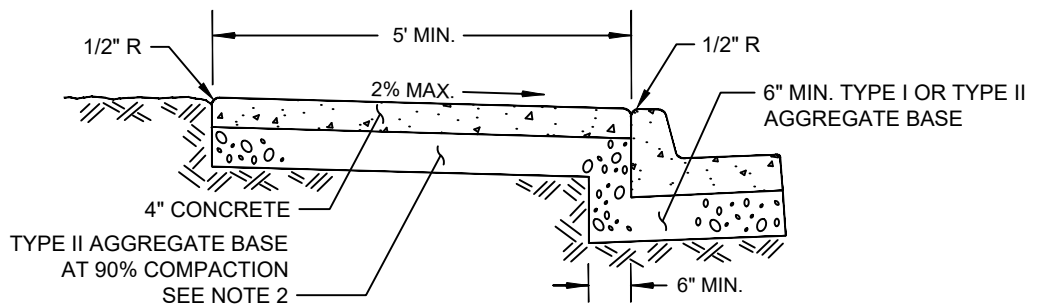

TYPICAL SECTION

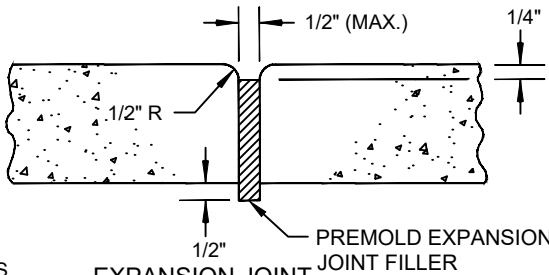

EXPANSION JOINT

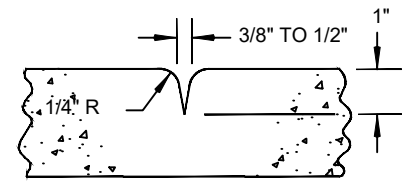

WEAKENED PLANE JOINT (TOOL CUT)

NOTES

- ON ALL CURB RETURNS A 1/2" EXPANSION JOINT SHALL BE CONSTRUCTED BETWEEN THE BACK OF CURB AND THE SIDEWALK FOR THE ENTIRE LENGTH OF THE RETURN.
- THE TYPE II AGGREGATE BASE THICKNESS IS SHOWN ON THE TYPICAL SECTION DRAWINGS 202 - 207.
- LONGITUDINAL WEAKENED PLANE JOINT REQUIRED AT MIDPOINT OF SIDEWALK 10' OR WIDER.
- WHEN INSTALLED WITHIN THE ROW, SIDEWALK GRADE IS PERMITTED TO EQUAL THE GENERAL GRADE ESTABLISHED FOR THE ADJACENT STREET OR HIGHWAY.
- OBJECTS WITH LEADING EDGES MORE THAN 2.25 FT. AND NOT MORE THAN 6.7 FT. ABOVE FINISH SURFACE SHALL PROTRUDE 4 IN. MAXIMUM HORIZONTALLY INTO PEDESTRIAN CIRCULATION PATH. THE MINIMUM HEIGHT, MEASURED VERTICALLY FROM THE BOTTOM OF THE SIGN TO THE TOP OF SIDEWALK, OF SIGNS INSTALLED ABOVE SIDEWALKS, SHALL BE 7 FT.
- PEDESTRIAN ACCESS ROUTE SHALL HAVE A CROSS SLOPE OF NO GREATER THAN 2%, REGARDLESS OF CONSTRUCTION TOLERANCES.

AGENCY APPROVED	B	C	H	L	M	N	R
-----------------	---	---	---	---	---	---	---

SPECIFICATION REFERENCE	
302	AGGREGATE BASE
501	CONCRETE
502	CONCRETE STRUCTURES
707	JOINT MATERIAL

UNIFORM STANDARD DRAWINGS CLARK COUNTY AREA	
SIDEWALK	
DATE 01-09-20	DWG. NO. 234