

**RESIDENTIAL TWO-WAY LOCAL OR CUL-DE-SAC
(OPTION "A")**

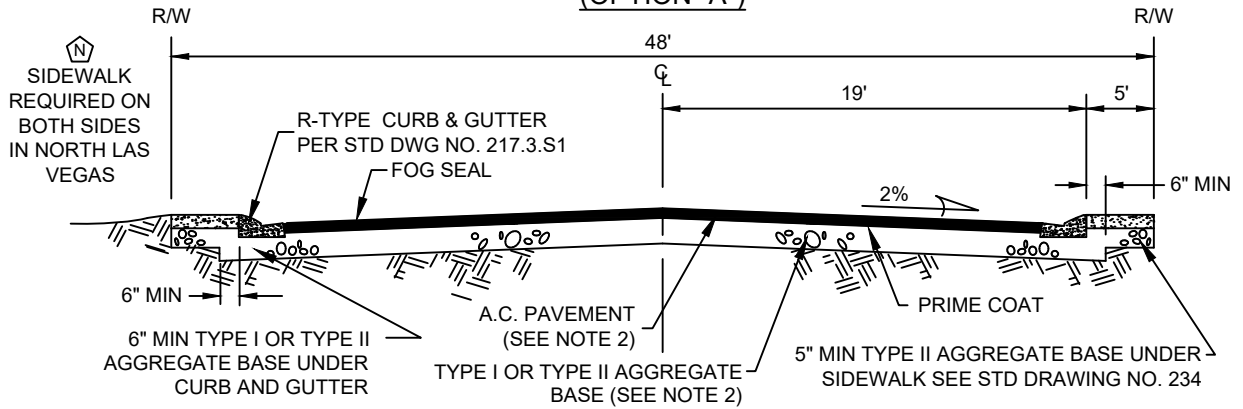

**RESIDENTIAL TWO-WAY LOCAL, CUL-DE-SAC
(OPTION "B")**

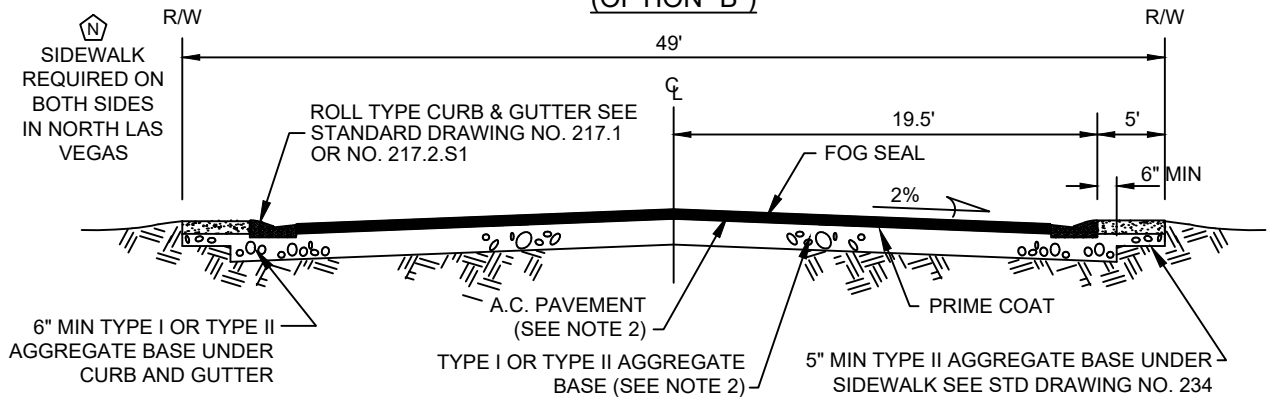

**RESIDENTIAL TWO-WAY LOCAL, CUL-DE-SAC
(OPTION "C")**

NOTES

1. FINAL A.C. PAVEMENT SURFACE SHALL BE 1/4" MAXIMUM ABOVE LIP OF GUTTER AFTER COMPACTION, EXCEPT WHERE THERE IS OVERLAP WITH PEDESTRIAN ACCESS ROUTES. CONNECTIONS BETWEEN PAVEMENT SURFACES, GUTTERS, AND CURB RAMPS WITHIN PEDESTRIAN ACCESS ROUTES SHALL HAVE NO VERTICAL SURFACE DISCONTINUITIES GREATER THAN 1/4", REGARDLESS OF CONSTRUCTION TOLERANCES.
2. STRUCTURAL SECTION SHALL BE IN ACCORDANCE WITH STANDARD SPECIFICATION SECTION 401 AND STD. DWG. NO. 200.1.
3. RESIDENTIAL ONE-WAY STREET SHALL NOT EXCEED ONE THOUSAND FEET OR TWENTY RESIDENTIAL LOTS IN LENGTH, WHICHEVER IS LESS.

SPECIFICATION REFERENCE		AGENCY APPROVED	C	L	N
302	AGGREGATE BASE	UNIFORM STANDARD DRAWINGS CLARK COUNTY AREA			
401	BITUMINOUS PAVEMENT				
406	PRIME COAT	LOCAL RESIDENTIAL URBAN AREA STREET SECTION			
407	FOG COAT				
501	CONCRETE	DATE 01-09-20 DWG. NO. 206.S3			