

**BEHIND CURBSIDE SIDEWALK**

(EASEMENT MAY BE REQUIRED)  
(SEE USD 320.1)

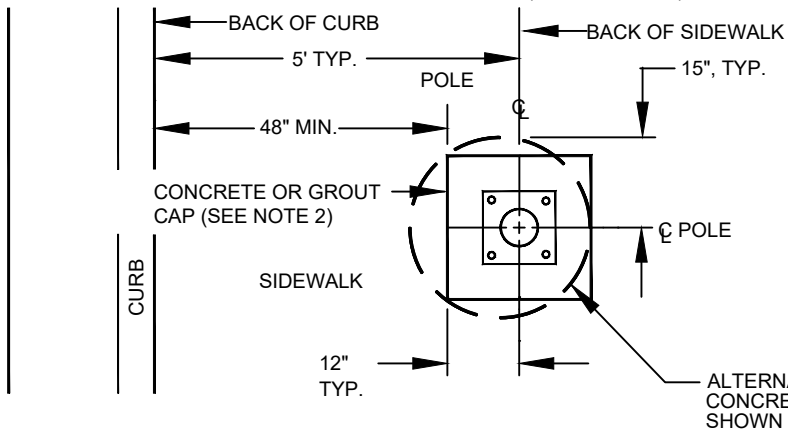

**NOTES**

1. FOUNDATIONS SHALL BE LOCATED OUTSIDE OF THE SIDEWALK WHENEVER FEASIBLE. A CLEARANCE OF 48" SHALL BE MAINTAINED ON PEDESTRIAN ACCESS ROUTE.
2. FOUNDATION CAP SHALL BE CONCRETE OR GROUT AS DESIGNATED BY THE ENTITY ENGINEER.
3. REFER TO STANDARD DRAWING NO. 321 FOR FOUNDATION DETAIL.

**BACK PORTION OF CURBSIDE SIDEWALK (NOT FOR NEW CONSTRUCTION)**

(EASEMENT MAY BE REQUIRED)  
(SEE USD 320.1)

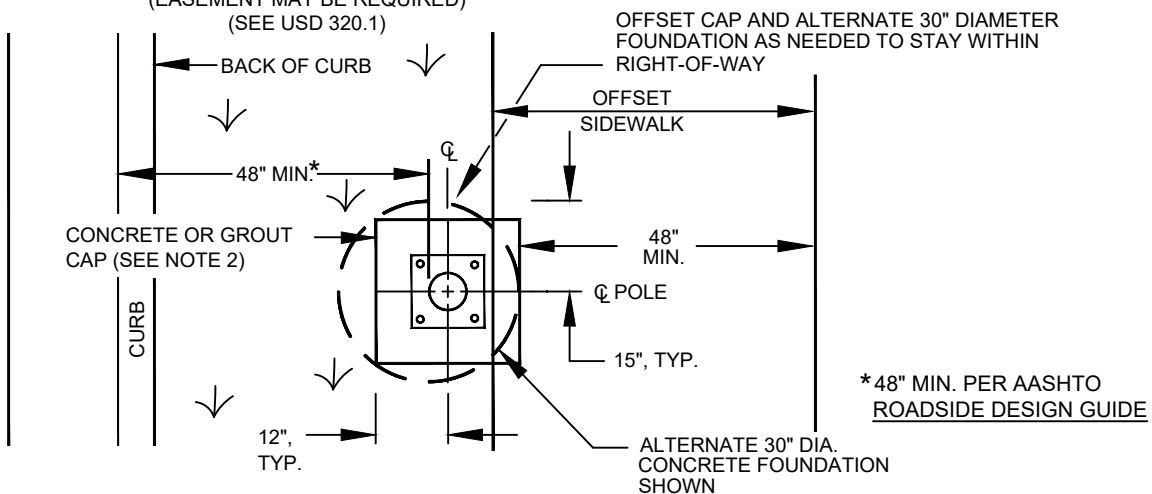

**OPEN AREA OR BETWEEN CURB AND SIDEWALK**

AGENCY APPROVED	B	C	H	L	M	N	R
-----------------	---	---	---	---	---	---	---

SPECIFICATION REFERENCE	
501	PORTLAND CEMENT CONCRETE
623	TRAFFIC SIGNALS & STREETLIGHTING

UNIFORM STANDARD DRAWINGS CLARK COUNTY AREA	
LIGHTING STANDARD SETBACK	

DATE 03-12-20	DWG. NO. 320
---------------	--------------