

PLAN

1/2" EXPANSION JOINT AT ALL COLD JOINTS, AT BEGINNING AND END OF RETURN AND AT 300' MAX. INTERVALS FOR EXTRUDED CURB AND 30' MAX. INTERVALS FOR FORMED CURB. FOR JOINT DETAIL SEE STANDARD DRAWING NUMBER 234

NOTES:

1. 1" BATTER ON GUTTER FACE OPTIONAL.
2. WHERE LONGITUDINAL SLOPE IS LESS THAN 0.4%, THE FLOW LINE SHALL BE WATER TESTED.

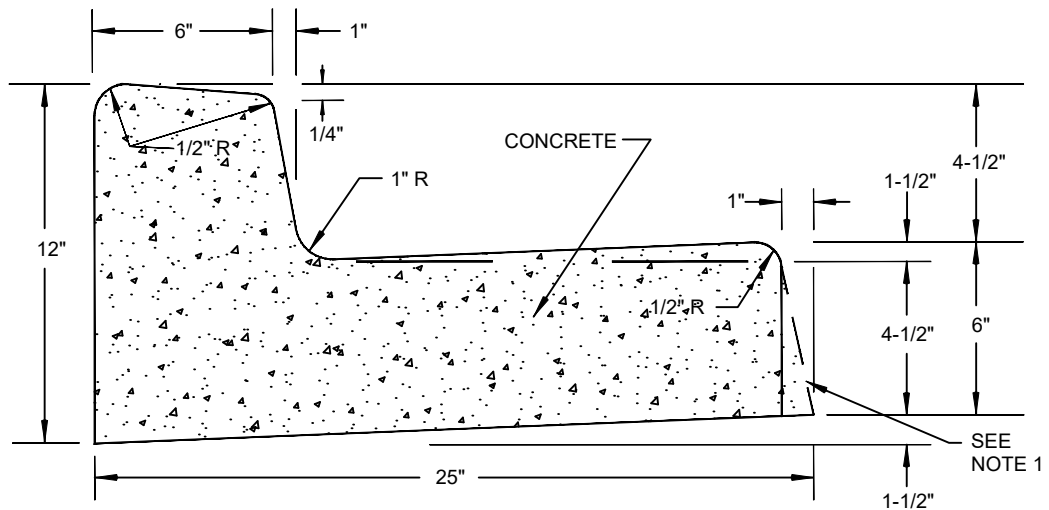

TYPICAL SECTION

SPECIFICATION REFERENCE		AGENCY APPROVED					
		B	C	H	L	M	N
501	CONCRETE	UNIFORM STANDARD DRAWINGS CLARK COUNTY AREA					
502	CONCRETE STRUCTURES						
707	JOINT MATERIAL	"L" TYPE CURB AND GUTTER					
		DATE 12-14-00		DWG. NO. 216			