

**RESIDENTIAL TWO-WAY LOCAL OR CUL-DE-SAC  
(OPTION "A")**

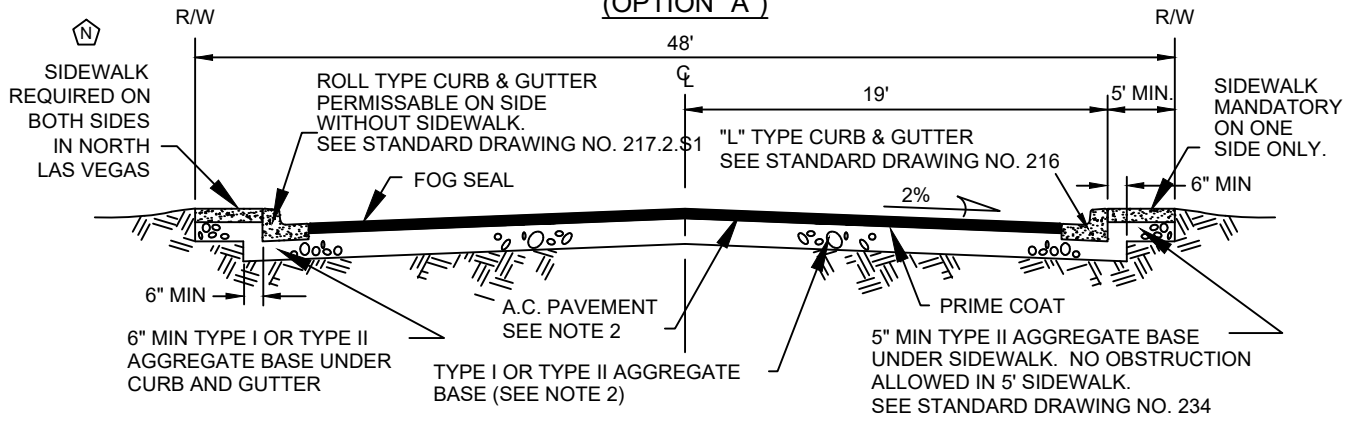

**RESIDENTIAL TWO-WAY LOCAL, CUL-DE-SAC (OPTION "B")  
(NOT ALLOWED IN CLV OR CLARK COUNTY)**

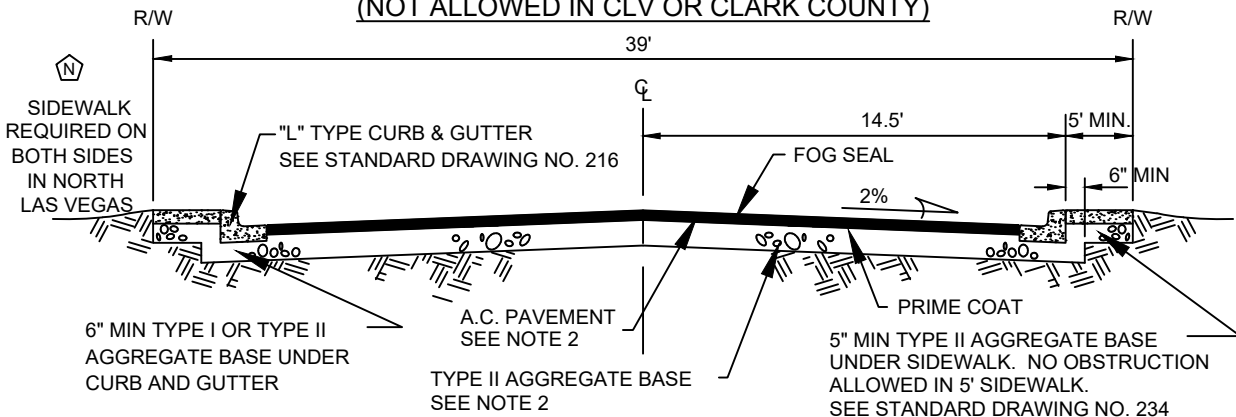

**RESIDENTIAL ONE-WAY (NOT ALLOWED IN CLV OR CLARK COUNTY)**

**NOTES**

1. FINAL A.C. PAVEMENT SURFACE SHALL BE 1/4" MAXIMUM ABOVE LIP OF GUTTER AFTER COMPACTION, EXCEPT WHERE THERE IS OVERLAP WITH PEDESTRIAN ACCESS ROUTES. CONNECTIONS BETWEEN PAVEMENT SURFACES, GUTTERS, AND CURB RAMPS WITHIN PEDESTRIAN ACCESS ROUTES SHALL HAVE NO VERTICAL SURFACE DISCONTINUITIES GREATER THAN 1/4", REGARDLESS OF CONSTRUCTION TOLERANCES.
2. STRUCTURAL SECTION SHALL BE IN ACCORDANCE WITH STANDARD SPECIFICATION SECTION 401 AND STANDARD DRAWING NO. 200.1.
3. RESIDENTIAL ONE-WAY STREET SHALL NOT EXCEED ONE THOUSAND FEET OR TWENTY RESIDENTIAL LOTS IN LENGTH, WHICHEVER IS LESS.

AGENCY APPROVED C L N

SPECIFICATION REFERENCE	
302	AGGREGATE BASE
401	BITUMINOUS PAVEMENT
406	PRIME COAT
407	FOG SEAL
501	CONCRETE

UNIFORM STANDARD DRAWINGS CLARK COUNTY AREA	
SUPPLEMENTAL DRAWING	
LOCAL RESIDENTIAL URBAN AREA STREET SECTIONS	
DATE 01-09-20	DWG. NO. 206.S1