

**ARTERIAL WITH
MEDIAN ISLAND**

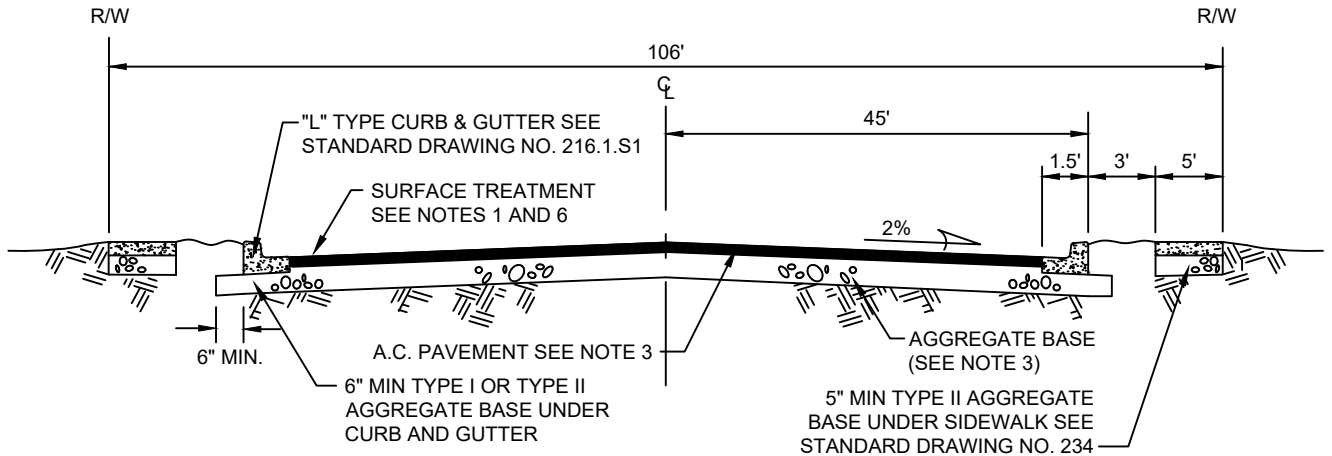

**ARTERIAL WITHOUT
MEDIAN ISLAND**

NOTES

1. FINAL A.C. PAVEMENT SURFACE (INCLUDING UTACS OR OPEN GRADE) SHALL BE 3/4" MAXIMUM ABOVE LIP OF GUTTER AFTER COMPACTION, EXCEPT WHERE THERE IS OVERLAP WITH PEDESTRIAN ACCESS ROUTES. CONNECTIONS BETWEEN PAVEMENT SURFACES, GUTTERS, AND CURB RAMPS WITHIN PEDESTRIAN ACCESS ROUTES SHALL HAVE NO VERTICAL SURFACE DISCONTINUITIES GREATER THAN 1/4", REGARDLESS OF CONSTRUCTION TOLERANCES. DENSE GRADE SHALL BE FLUSH WITH LIP OF GUTTER.
2. STRUCTURAL SECTION SHALL BE IN ACCORDANCE WITH STANDARD SPECIFICATION SECTION 401 AND STANDARD DRAWING NO. 200.
3. THIS STANDARD IS AN ALTERNATE STREET SECTION TO BE USED AT LOCATIONS DETERMINED BY EACH LOCAL JURISDICTION. NO ABOVE GROUND OBJECTS SHALL BE PLACED WITHIN THE 5 FOOT SIDEWALK.
4. UNDERGROUND DRY UTILITIES SHALL BE PLACED IN A UTILITY CORRIDOR UNDER THE SIDEWALK.
5. OVERLAY 1" UTACS UNLESS OTHERWISE REQUIRED BY THE AGENCY.

		AGENCY APPROVED	B	C	H	L	M	N	R	
SPECIFICATION REFERENCE		UNIFORM STANDARD DRAWINGS CLARK COUNTY AREA								
302	AGGREGATE BASE	SUPPLEMENTAL DRAWING								
401	BITUMINOUS PAVEMENT	PRIMARY ARTERIAL								
403	OPEN GRADE	COMPLETE STREET ALTERNATIVE								
501	CONCRETE									
		DATE 01-09-20	DWG. NO. 203.1.S1							